

Models with 14", 18" and 24" Wave Widths

*Exceptional value, proven performance,
and flexible configurations
to meet all your wave soldering needs*

- Streamlined Design for Easy Maintenance and Cleaning
- User Friendly Programming and Operation
- Exceptional accuracy and repeatability
- Durable Construction



**LEAD-FREE
Soldering Capable**

14", 18" and 24" WAVE SOLDER MACHINES

The ultimate in sophistication and simplicity. Standard machines have features shown here and more...

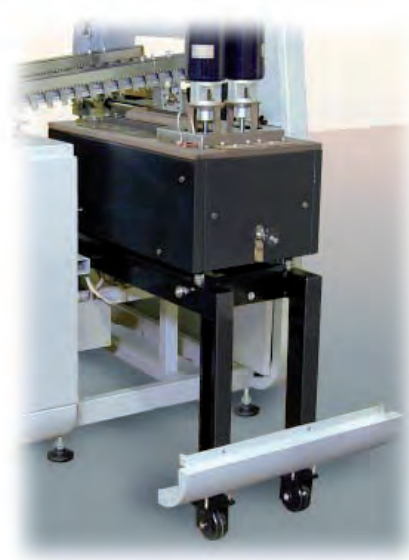
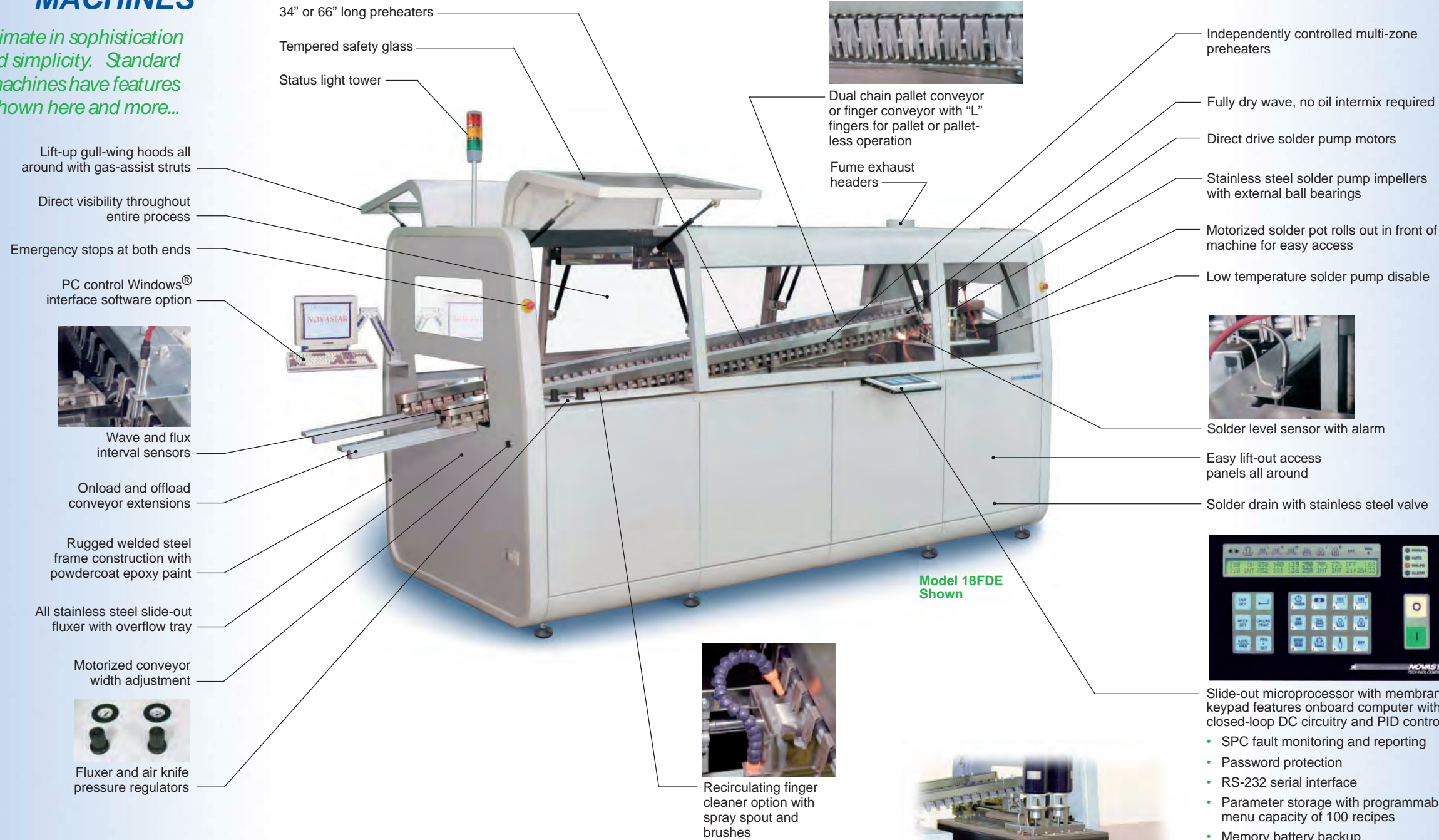

Model 18FDE Shown

Fluxer Configuration

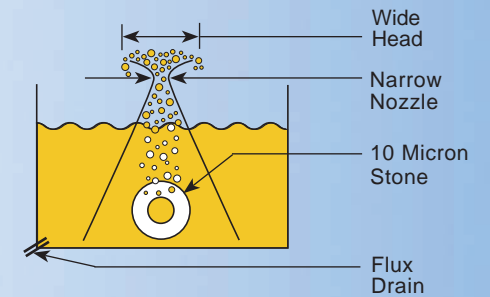

Preheater Configuration

For Large Boards (shown with IR elements)

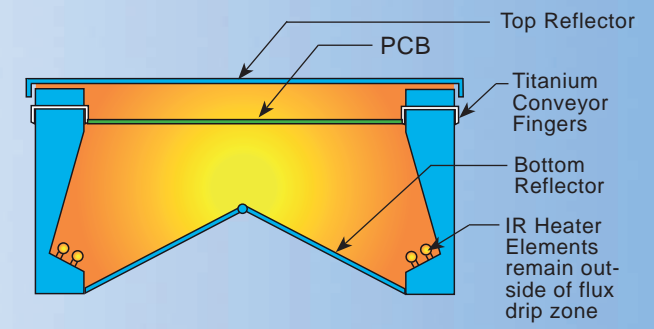

For Small Boards (shown with convection elements)

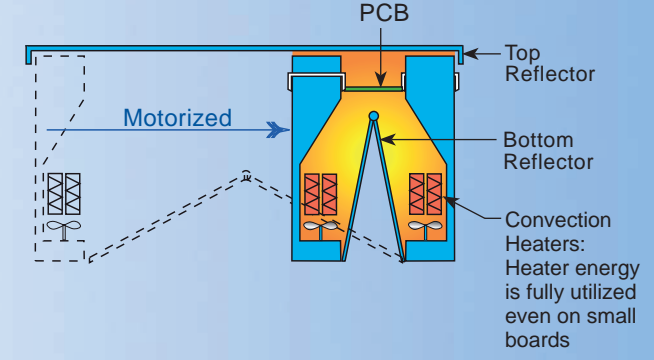

Solder Module Configuration

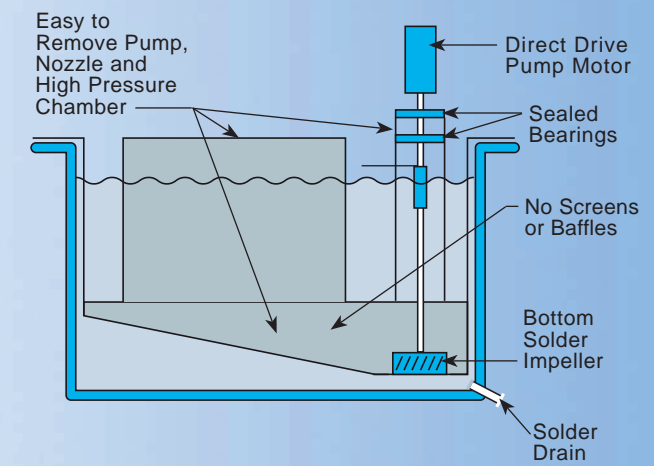

- Slide-out microprocessor with membrane keypad features onboard computer with closed-loop DC circuitry and PID control
- SPC fault monitoring and reporting
- Password protection
- RS-232 serial interface
- Parameter storage with programmable menu capacity of 100 recipes
- Memory battery backup
- 7 day skip timer

OPTIONS

- Lead Free Soldering Capable
- Finger cleaner
- Spray fluxer
- Nitrogen inerting with GasMizer™ feature
- PC interface Windows™ software
- Special applications & requests
- Full finger option

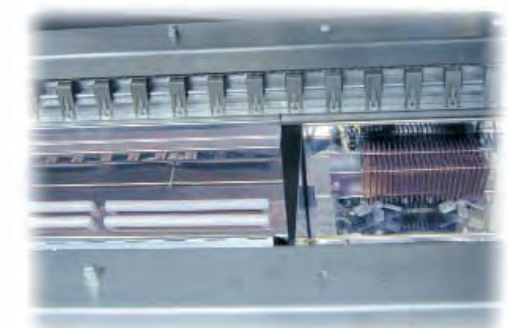

Flux nozzle with air knife



Turbulent wave for SMD and laminar wave for through-hole soldering

Independently controlled infrared and forced air convection preheaters compatible with VOC-free fluxes

Motorized roll-out pot provides easy access. Pot rolls to front of machine: requires less floor space.

Wave Solder Machines for Lead-Free Soldering

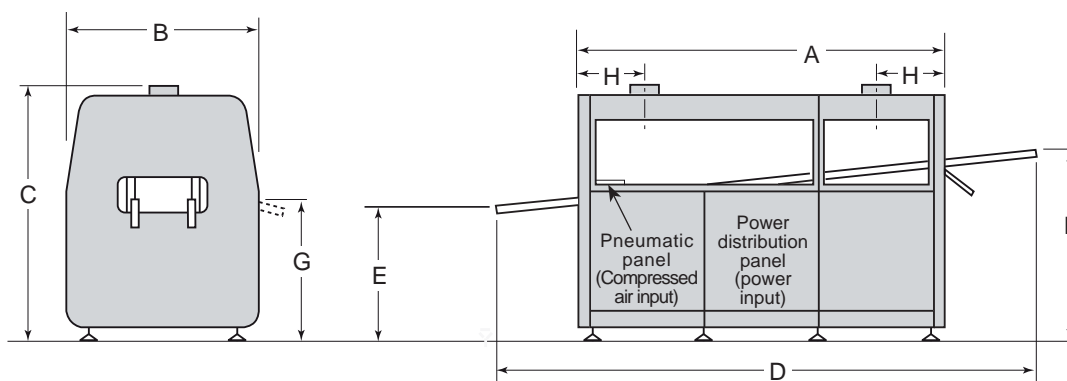

DIMENSIONS & SPECIFICATIONS (ENGLISH/METRIC)

MODEL	14PD/FD/PS/FS-HT	18PD/FD/PS/FS-HT	24PD/FD/PS/FS-HT
A: Footprint length	95/2413	95/2413	95/2413
B: Width (in/mm)	55/1397	55/1397	61/1550
C: Height (in/mm)	63/1600	63/1600	63/1600
D: Overall length (in/mm)	F: 127, P: 151 F: 3226, P: 3835	F: 127, P: 151 F: 3226, P: 3835	F: 127, P: 151 F: 3226, P: 3835
E: Onload height	33.5/850	33.5/850	33.5/850
F: Offload height (in/mm)	F: 46.5, P: 51.5 F: 1181, P: 1308	F: 46.5, P: 51.5 F: 1181, P: 1308	F: 46.5, P: 51.5 F: 1181, P: 1308
G: Controller height	39/990	39/990	39/990
H: Header from end	18/457	18/457	18/457
Power*	220 VAC, 60 Hz 3Ø, 30A	220 VAC, 60 Hz 3Ø, 50A	220 VAC, 60 Hz 3Ø, 50A
Foam Fluxer Tank	1 gal/4 ltrs	1.5 gal/6 ltrs	2 gal/8 ltrs
Solder Pot Capacity	500 lbs/225 kgs	1000 lbs/450 kgs	1325 lbs/600 kgs
Max Wave Height	0-3/8"/0-10 mm	0-3/8"/0-10 mm	0-3/8"/0-10 mm
Wave Width	14"/350 mm	18"/460 mm	24"/600 mm
Minimum Board Width	2"/50 mm	2"/50 mm	2"/50 mm
Max Preheat Temp	356 °F/180 °C	356 °F/180 °C	356 °F/180 °C
Preheat Power I	4.8 kW	4.8 kW	4.8 kW
Preheat Power II	NA	NA	NA
Preheat Power III	2.0 kW	2.0 kW	2.0 kW
Total Preheat Power	6.8 kW	6.8 kW	6.8 kW
Max Solder Pot Temp	575 °F/300 °C	575 °F/300 °C	575 °F/300 °C
Max Lead Free Pot Temp	662 °F/350 °C	662 °F/350 °C	662 °F/350 °C
Solder Pot Power	4.5 kW	7.5 kW	9.5 kW
Approx Warm-up Time	100 minutes	120 minutes	150 minutes
Max Conveyor Speed	8 ft/min (2.5 m/min)	8 ft/min (2.5 m/min)	8 ft/min (2.5 m/min)
Compressed Air	10 CFM @ 60 PSI (17 m ³ /hr @ 4 bar)		
Exhaust requirements	Two 6" dia. headers @ 300 CFM each (600 CFM total) Two 150 mm dia. headers @ 500 m ³ /hr each (1000 m ³ /hr total)		
Conveyor	6 degree incline, left to right operation, front fixed rail - rear moveable rail (motorized)		

P= pallet conveyor, F= finger conveyor, S= single wave, D= dual wave

*Other electrical configurations available; contact factory for details